

## Residential Air

# 28-1000/28-1010 Ultraviolet System

Owners Guide  
Patent Pending



This page left blank intentionally

## 28-1000/28-1010 Ultraviolet System

Indoor air quality products from Altru-V<sup>®</sup> are designed to help make your home more comfortable and increase the indoor air quality of your home.

For more information on ways to improve the air inside your home, please visit Health House website at:

[www.healthhouse.org](http://www.healthhouse.org)

and the American Lung Association website at: [www.lungusa.org](http://www.lungusa.org)

The American Lung Association and its Health House program do not endorse products.

For more information about Altru-V<sup>®</sup> indoor Air Quality products, visit:

<http://www.altruv.com/>

For Toll-Free telephone sales information and product support  
Mon - Friday between the hours of 8:00 am and 5:00 pm Pacific Time  
**(877) PUREUVC (787-3882)**

**System requirements: 120 (+10%/-15%) VAC / 60Hz / 1.1A**

### **Product Registration**

Thank you for purchasing this product from UVDI! Prior to any other installation activities, please proceed with registering your product via the web at <http://www.altruv.com> or by returning the enclosed self-addressed postcard. Product registration will insure that your warranty is handled in a proper and expeditious manner. In addition, it will allow UVDI to provide you with important updates regarding your new product including reminders of when replacement parts are needed and also make you eligible for future parts discounts.

## HOW YOUR ULTRAVIOLET AIR TREATMENT SYSTEM OR SURFACE TREATMENT SYSTEM WORKS

Depending on installation, your Ultraviolet System can operate as an Air Treatment System or as a Surface Treatment System.

### Air Treatment System

Installed in the return air duct of your system, your Ultraviolet Treatment System kills a high percentage of airborne germs circulation through your forced air heating and cooling system. Individual results depend on careful installation and maintenance and on the actual amount of time your system fan operates.

See Figure 1.

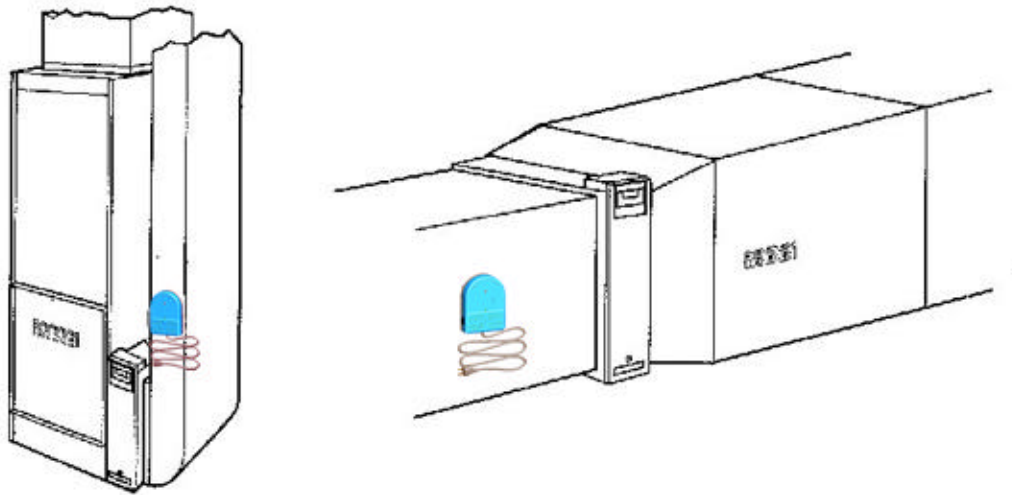

**Figure 1 – Typical Air Treatment System installations**

## Surface Treatment System

When installed next to the cooling coil of your system, your Ultraviolet Surface Treatment System prevents a high percentage of the growth of micro-organisms such as mold that may grow on duct surfaces, coils, and drain pans. Individual results depend on careful installation and maintenance. See Fig 2.

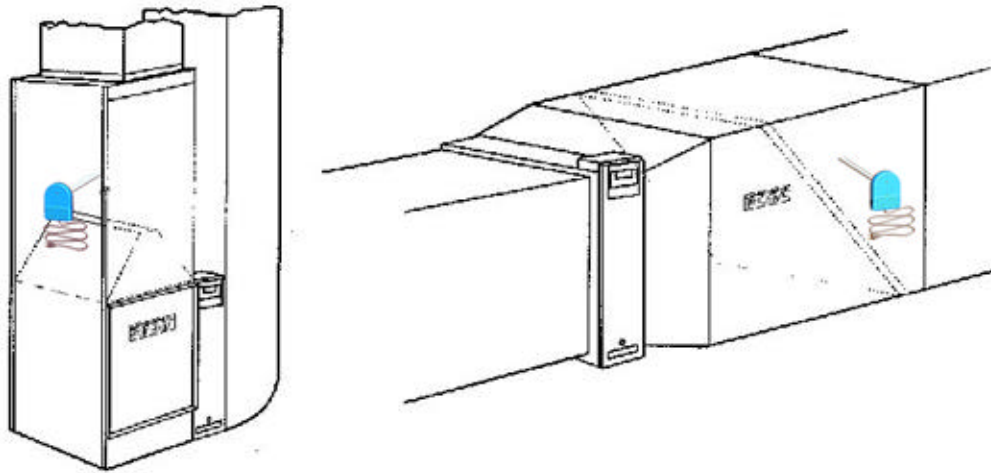

Figure 2 – Typical Surface Treatment installations

You can capture and minimize micro-organisms passing through your forced air system when you combine your UV System with a high-efficiency air filtration system like a Carbon or HEPA air cleaner. Talk to your installer about adding these products to your UV System and provide added protection for you and your family.

## BE SURE TO READ WARNINGS AND CAUTIONS BEFORE USING YOUR UV SYSTEM



### **▲ WARNING**

**UV Light Hazard.**

**Harmful to bare skin and eyes.**

**Can cause temporary or permanent loss of vision.**

Never look at bulbs while illuminated.

View illumination only through light indicator located on lamp cover.

To prevent exposure to ultraviolet light, disconnect power to Ultraviolet System before servicing any part of heating and air condition system.

Do not mount in location that allows ultraviolet light to be seen after installation.

Do not attempt to bypass duct mount switch.

Do not attempt to open housing; unit is sealed to prevent ultraviolet light exposure.



### **CAUTION**

**Personal Injury Hazard.**

**Power supply can cause electrical shock.**

Disconnect power supply before cleaning or replacing ultraviolet bulb(s).

Do not open base unit or lamp cover; there are no user-serviceable components inside.



### **CAUTION**

**UV Lamp Hazard.**

**Harmful to bare skin.**

**Can cause severe burns.**

Disconnect power 15 minutes before removing the ultraviolet bulb(s).



## **MERCURY NOTICE**

This device contains mercury in the sealed ultraviolet bulb(s). Do not place your used bulb(s) in the trash. Dispose of properly.

### **Broken Bulb Cleanup.**

#### **Do Not use a household vacuum.**

Sweep debris (phosphor/glass) into a plastic bag and dispose of properly. Contact your local waste management authority for instructions regarding recycling and the proper disposal of old bulb(s).

**TO PREVENT ELECTRIC SHOCK; MATCH WIDE BLADE OF PLUG TO WIDE SLOT.**

**POUR EVITER LES CHOCS ELECTRIQUES, INTRODUIRE LA LAME LA PLUS LARGE DE LA FICHE DANS LA FENTE LA PLUS LARGE.**

## HOW YOU CAN CHECK YOUR ULTRAVIOLET SYSTEM

Your UV System is designed to prevent accidental contact with electrical voltage and with ultraviolet rays in the sealed unit – the ultraviolet lamp does not illuminate unless the base mounting plate is mounted on your forced air system duct.

It is recommended that every month you verify that your ultraviolet lamp is operating. *View the bulb only through the lamp light indicator on the lamp cover.* See Figure 3.

*Do not attempt to look into the duct at the illuminated bulb(s).*

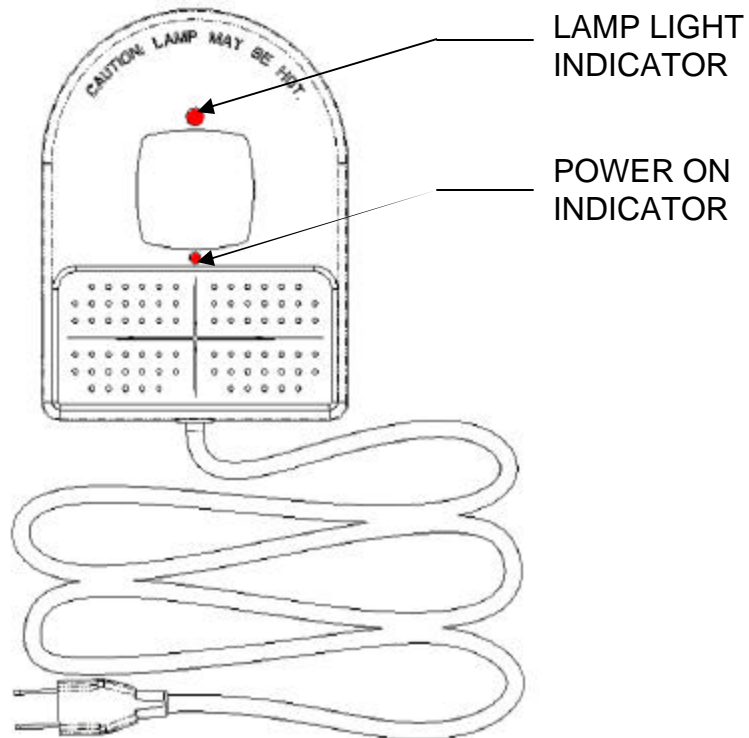

**Figure 3 – Lamp light and Power on indicators**



3. Rotate your lamp unit counterclockwise and gently pull the lamp unit to remove lamp assembly. See Figure 5.

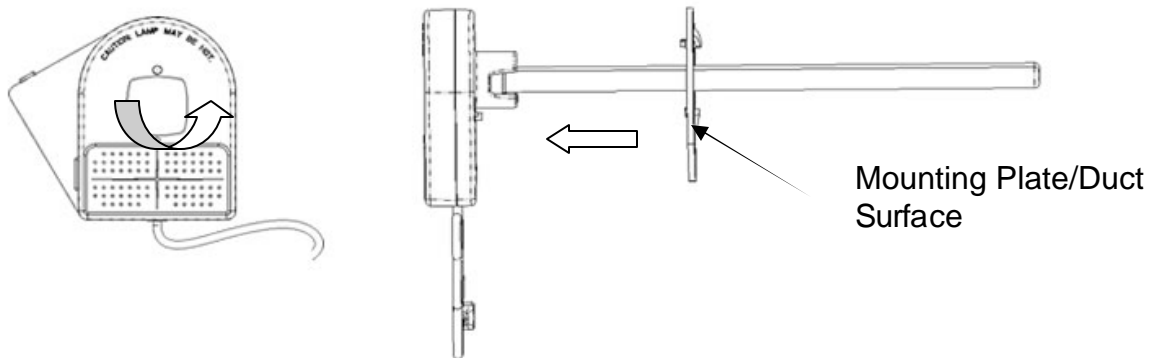

**Figure 5 – Remove lamp bulb**

4. Holding the lamp unit, wipe the lamp glass using a soft cloth dampened with glass cleaner. If you touch the lamp glass with your hands, be sure to clean the area of any oils left from bare hands. See Figure 6.

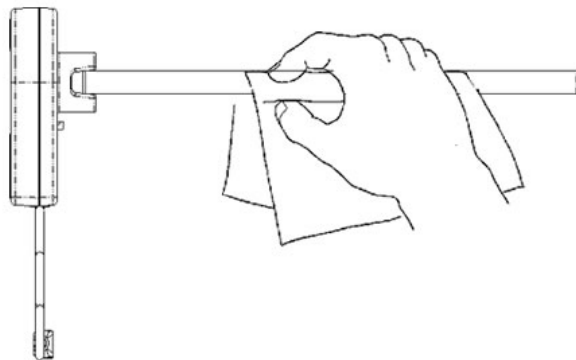

**Figure 6 – Clean glass with soft cloth**

## 28-1000/28-1010 Ultraviolet System

5. Also wipe away any dust that may have collected between the lamp light indicator on the base and the black bulb base. See Figure 7.

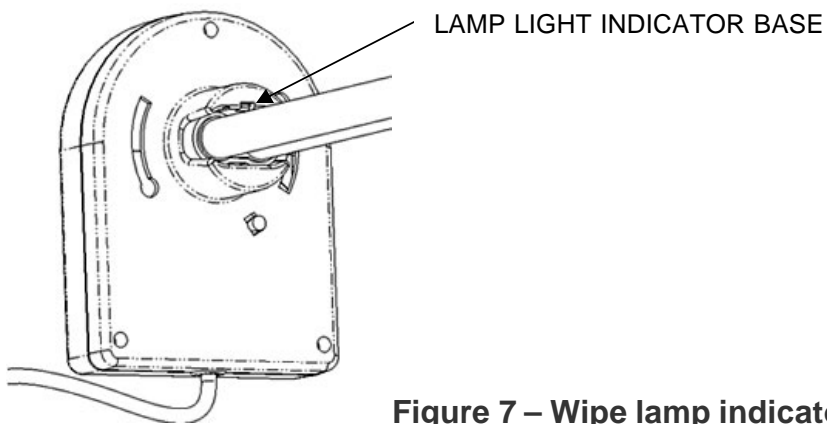

**Figure 7 – Wipe lamp indicator base**

6. Dry bulb with a clean, dry cloth.
7. Insert the bulb into the base mounting plate with the lamp unit at the approximately 3 o'clock position. Continue pushing downward gently and rotate unit clockwise until the unit is fully locked into position. See Figure 8.

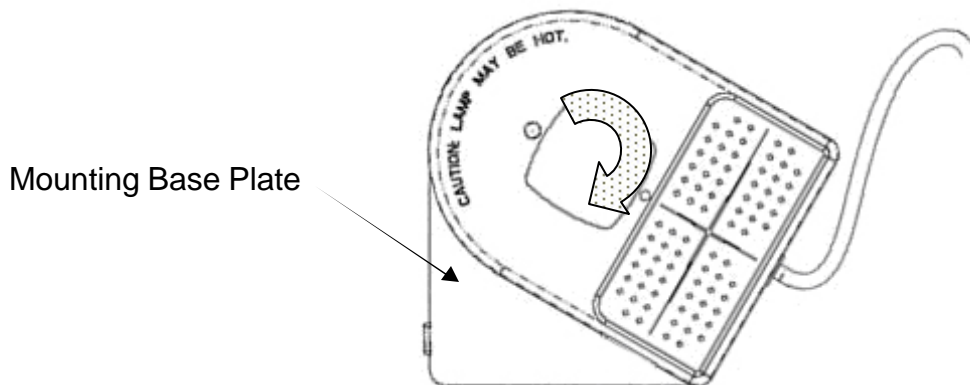

**Figure 8 – Position lamp assembly for insertion into base plate**

8. Reconnect power to your UV System.
9. Verify that your ultraviolet bulbs are operating by viewing only through the lamp light indicator on the lamp cover. Never look directly at your UV bulb while it is illuminated.

## 28-1000/28-1010 Ultraviolet System

10. Reconnect power to your heating and cooling system.

### Bulb Replacement

Annual replacement of the bulb in your ultraviolet lamp is required to maintain effectiveness.

1. Obtain the correct replacement bulb for your unit. See Table 1.

**Table 1 - Select a Replacement Bulb**

Unit Description	Replacement Bulb	Wattage
28-1000	28-3010	36
28-1010	28-3011	60

2. Disconnect the power to your heating and cooling system
3. Unplug or turn off power to your UV system and allow cooling for at least 15 minutes.
4. Rotate the lamp assembly counterclockwise and gently pull the lamp assembly to remove lamp assembly from base mounting plate.
5. Remove bulb. See figure 5.
6. To remove lamp bulb from UV unit, grasp the lamp unit in one hand, and pull straight apart. See Figure 9.

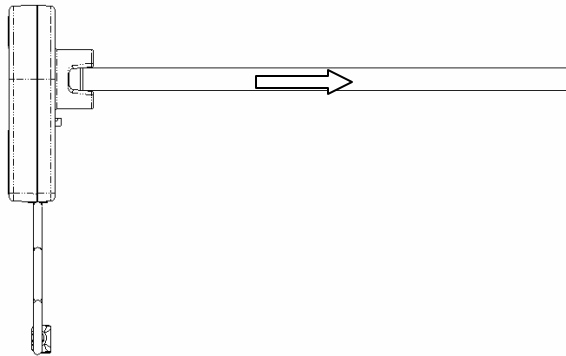

**Figure 9 – Removing bulb from UV unit**

## 28-1000/28-1010 Ultraviolet System

7. Insert the bulb into the base continually pushing gently into the lamp base as shown in Figure 10.

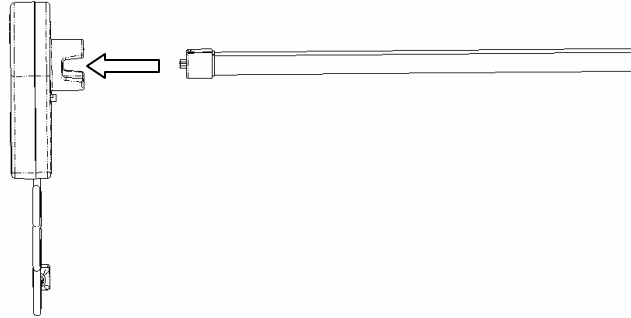

**Figure 10 – Replacing lamp bulb into UV unit**

8. Reinstall unit into duct mounting plate as show in figure 5. Never look directly at your bulb while illuminated.
9. Reconnect power to your heating and cooling system.

**Notes**

### EQUIPMENT WARRANTY

**UltraViolet Devices, Inc. (UVDI), warrants to original Buyer for one year** from the date of original installation, or eighteen (18) months from date of shipment, whichever comes first, that its goods are free from defect in material and workmanship under normal use and service. **UVDI's** obligation under this warranty shall be limited to the repair or replacement of those goods which prove defective, provided that such products are installed, maintained, and operated for the purpose and in the manner intended and for which **UVDI** instructs or recommends. Neither **UVDI** nor its dealers shall be liable for any special or consequential damages directly or indirectly arising from the design, construction, installation, servicing, or operation of the goods. THIS IS **UVDI'S** SOLE WARRANTY. NEITHER **UVDI** NOR ITS DEALERS MAKE ANY OTHER WARRANTY OF ANY KIND, EXPRESSED OR IMPLIED. ALL IMPLIED WARRANTIES OF MERCHANTABILITY AND FITNESS FOR A PARTICULAR PURPOSE WHICH EXCEED **UVDI'S** AFFORRESTATED OBLIGATIONS ARE HEREBY DISCLAIMED AND EXCLUDED FROM THIS WARRANTY.

**UVDI** AND ITS DEALERS' LIABILITY UNDER THIS WARRANTY SHALL IN NO EVENT EXCEED THE COST OF THE GOODS SOLD UNDER THIS CONTRACT OF SALE. **UVDI** neither assumes, nor authorizes any person to assume for it, any obligation in connection with the goods. This warranty shall not apply to any goods (a) which have been subjected to misuse, tampering, negligence, or accidents; or (b) the serial numbers of which have been altered, defaced, or removed; or (c) which have been used in a manner contrary to **UVDI's** instructions or recommendations. Buyer shall not return to **UVDI** any allegedly defective goods without **UVDI's** prior written authorization. This warranty may not be assigned or transferred.

#### **Product Registration**

It is highly recommended that you register your product via the web at <http://www.altruv.com/> or return the enclosed self-addressed postcard to UVDI. Product registration will insure that your warranty is handled in a proper and expeditious manner. In addition, it will allow UVDI to provide you with important updates regarding your new product including reminders of when replacement parts are needed and also make you eligible for future parts discounts.



Manufactured by:



26145 Technology Drive  
Valencia, CA 91355  
(877) PUREUVC  
(661) 257-4698 fax  
[www.uvdi.com](http://www.uvdi.com)

*Specifications subject to change without notice.  
©Altru-V and V-Ray are brands owned by UVDI.  
Copyright © 2004 by UltraViolet Devices, Inc. All rights reserved*

This page left blank intentionally